

LITTLE DAVID

SEALER LD-Xss RTE



WASH DOWN CASE SEALER

The LD-Xss RTE is a redesign of our revolutionary wash down stainless steel case sealer. It is the ideal case sealing solutions for ready-to-eat or cooked food processing operations that take extra precautions to eliminate bacteria and other foodborne pathogens.

PERFORMANCE & DESIGN FEATURES:

Quick change from 2" to 3" tape in the field

Easy access motor for quick change time

Quick disconnect electrical cabling

Adjustable height levelers

Quick release drive belts can be removed and replaced in a matter of seconds, not minutes.

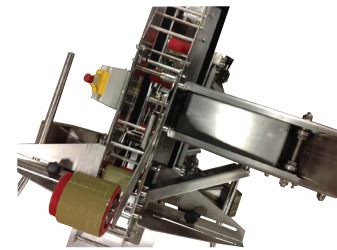

Angled surfaces maximize water shedding



Open design ensures all contact surfaces can be sanitized

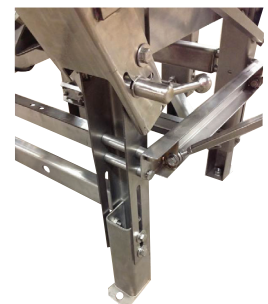

Standoffs used to minimize overlapping joints for full access while cleaning

LITTLE DAVID

LD-Xss RTE

SPECIFICATIONS OF THE LD-XSS RTE:

Power Requirements:

110 Volts, 60 cycle, single phase

Operating Speed:

Continuous belt drive, 80' per minute
(24.4m/min) (production rate depends on box
size and operator dexterity)

Closure Material:

Pressure sensitive tape

Weight:

269 lbs., uncrated

Case Capacity:

Length 4" to infinite, Width 4.5" to 27", Height
4.5" to 24" (certain length x width x height
combinations may not process due to unstable
conveying conditions)

OPTIONS OF THE LD-XSS RTE

- Recommended spare parts kit
- Spare CAC60 tape cartridge
- 3 Phase motor (any voltage)
- Stainless steel top squeezers
- Stainless steel front pack table
- Stainless steel casters
- NEMA 4 Wiring-enclosure-switch & motor
with epoxy gear reducer

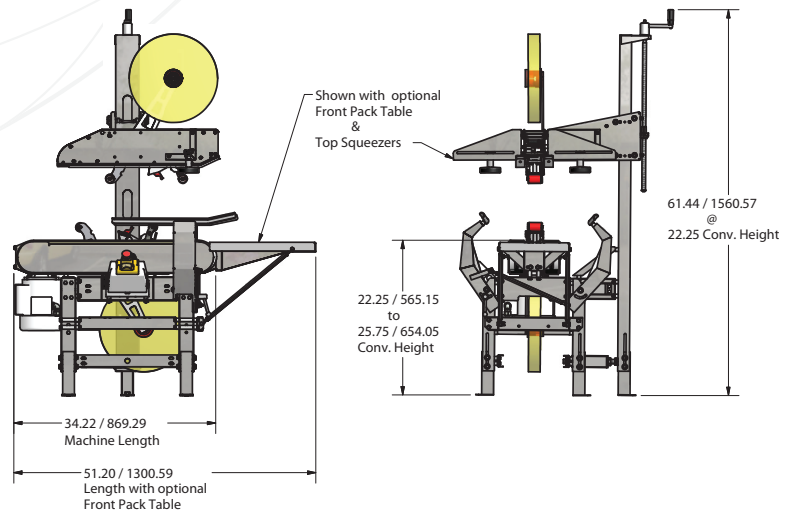
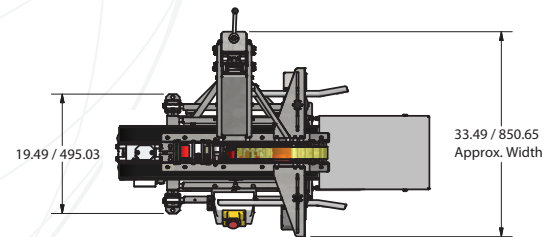

DISTRIBUTED BY:

LOVESHAW

2206 Easton Turnpike
P.O. Box 83, South Canaan, PA 18459
Tel: (570) 937-4921 Fax: (570) 937-3229
Toll Free: (800) 572-3434

LOVESHAW Europe

Unit 1 Newton Park
West Portway Industrial Estate
Andover, Hampshire, SP10 3SH
sales@loveshaw-europe.co.uk
Tel: +44 (0)1264 357 511
Fax: +44 (0) 1264 355 964